



Watertown Housing Authority

1091 Buckingham Street

Watertown, CT 06795

Watertown Housing Authority
Commissioner Report
November 13, 2024





Watertown Housing Authority

1091 Buckingham Street

Watertown, CT 06795

Wednesday, November 13, 2024

Regular Meeting – Truman Terrace, 6:00 p.m.

Agenda

1. Roll Call
2. Chairwoman's Report
3. Approval of Minutes
 - a. Regular Meeting, Buckingham Terrace, October 9, 2024
4. Approval of bills paid in:
 - a. November 2024
5. New Business
 - a. Discussion and Possible Action on WHA 2025 Meeting Dates
6. Old Business
 - a. Laundry Machines
7. Property Manager's Report
 - a. Available Apartments
 - b. Work Orders
8. Resident Commissioner Report
9. Public Participation
10. Executive Session
 - a. Personnel Matters – Discussion and Possible Action concerning RSC Position
11. Regular Session with Possible Action
12. Adjournment

**WATERTOWN HOUSING AUTHORITY
1091 Buckingham Street
Watertown, CT 06795**

**Meeting Wednesday, October 9, 2024
Buckingham Terrace, 6:00 P.M.**

MINUTES

A meeting was held by the Housing Authority on Wednesday, October 9, 2024 at Buckingham Terrace – 6:00 P.M.

Chair Janelle Wilk called the meeting to order at 6:02 P.M.

1. Roll Call

Members Present:

Sharon Pratt – Resident Commissioner
Peter Mucciarone – Commissioner
Denise Russ – Commissioner
Janelle Wilk – Chairwoman

Absent: Dan DiVito – Vice Chairman

Others Present:

Russ Antonacci - Manager
Lori Finke - On-Site Property Manager

2. Chairwoman's Report:

Happy October! I hope everyone has been enjoying the nice weather we have been having. Please take a moment and send some good thoughts to everyone and everything down south. I would like to publicly thank Dan for running our last meeting in my absence and thank all commissioners who were able to attend that meeting.

I have received a couple of concerns that I would like to address tonight. I'm aware of many people's concerns and frustration with our washer and dryers. Lori has reached out numerous times and is now dealing with a supervisor to hopefully solve this problem. We have looked into other options but unfortunately there are not many.

I would also like to say that starting next month everything will go back to normal or to the way Sharon Pratt normally would conduct RC Business. She will resume going back to each site how she has done in the past.

3. Approval of Minutes

a. Regular Meeting Country Ridge, September 11, 2024

A motion was made by Denise Russ, and seconded by Peter Mucciarone to approve the Regular meeting minutes of September 11, 2024.

Discussion: none

Aye: Russ, Mucciarone

Nay: 0

Abstain: 2

4. Approval of Bills

a. September bills

Denise Russ had four questions. The first question was regarding the digital recorder. Lori responded that it was a new recorder for the monthly Commission meetings.

The second question was regarding the request for RSC petty cash in the amount of \$237.83. Lori responded that money will still be used to reimburse residents that are purchasing snacks for the coffee hours until the new RSC starts.

The third question was regarding the Amazon order for security camera, sash locks. Lori responded that one of the security cameras needed to be replaced. The sash locks were to replace broken locks on windows at Country Ridge.

The fourth question was regarding the \$20,880.00 bill from Complete. Lori and Janelle explained that the two retention ponds needed to be dug out so that they would work properly.

Motion was made by Denise Russ, and seconded by Pete Mucciarone to approve the September bills.

5. New Business
 - a. RSC Position
 - b. Lori will email Commissioners to gain available time and dates to perform an interview with a possible candidate.
 - i. Once received a special meeting will be scheduled.

6. Old Business
 - a. Door Bells
 - i. Lori presented three possible door bells with video.
 - ii. Motion was made by Denise Russ, and seconded by Peter Mucciarone to approve Lori to receive pricing on a less expensive regular doorbell.

7. Property Management Report
 - a. Available Apartments
 - a. Country Ridge: Currently one apartment is available and will be rented as of November 1, 2024.
 - b. Buckingham Terrace: Currently one apartment is available and will be rented as of November 15, 2024.
 - c. Truman Terrace has (1) open apartment that is currently being updated.
 - b. Work Orders
 - a. 29 workorders were opened between 9/9/24 - 10/3/24. (2) still open.

8. Resident Commissioner Report:
 - a. Sharon Pratt thanked everyone for their well wishes for her health recovery.
 - b. Sharon asked for confirmation that the window air conditioners at Truman Terrace must be removed before the cold weather. This was a past decision that was made by the Commissioners when the new windows were installed at Truman Terrace.
 - c. Sharon asked about the ability of smoking marijuana on the property even if it is medicinal. WHA has a No Smoking policy and Sharon is

asking if this should fall under the same guidelines. Sharon feels isn't fair that people are smoking and the smoke is affecting other residents. Chairwoman Janelle Wilk will follow up with Attorney Pilicy on this point.

9. Public Participation:

Deborah Manley CR 13 Spoke
Phyllis West BT B-7 Spoke
Clair Roberts BT E-4 Spoke

10. Adjournment:

A motion was made by Denise Russ and second by Peter Mucciarone to adjourn at 6:37 P.M.

Janelle Wilk, Chair
Watertown Housing Authority



WHA PAYABLES

11/11/2024
10:56 AM

Watertown Housing Authority
Accounts Payable
November 2024

Type	Date	Num	Name	Memo	Location	Amount
Bill	10/01/2024	TT A1	3J's Painting LLC	TT A1 prep & paint	Truman Terrace	2,230.00
Bill	10/01/2024	TT A1	3J's Painting LLC	TT A1 paint	Truman Terrace	249.34
Bill	10/20/2024	TT C20	3J's Painting LLC	TT C20 compound, sand and paint	Truman Terrace	180.00
Bill	10/25/2024	CR 22	3J's Painting LLC	CR 22 prep & paint walls, railing	Country Ridge	2,970.00
Bill	10/24/2024	123007 102424	Ace Hardware of Watertown	monthly charges	All	277.34
Bill	10/08/2024	1007	AHOVA Home Improvement LLC	TT broken window - to be reimb from Complete	Truman Terrace	450.00
Bill	10/21/2024	1JXR-17P3-37MV	Amazon.com	door lever, shredder	All	228.74
Bill	10/22/2024	1WGF-VYRP-F194	Amazon.com	CR wireless doorbell	Country Ridge	16.98
Bill	11/07/2024	1MJY-CG9L-D34X	Amazon.com	wireless doorbells	All	96.29
Bill	11/07/2024	1LWK-71L3-C3FJ	Amazon.com	wireless doorbells	All	96.29
Bill	11/07/2024	1MPH-K7X3-C4YY	Amazon.com	wireless doorbells	All	96.29
Bill	11/07/2024	1LQV-PCR1-9YR4	Amazon.com	wireless doorbells	All	96.29
Bill	11/04/2024	486599	Carpets Plus, Inc.	BT E5 installation	Buckingham Terrace	2,058.00
Bill	11/01/2024	519617	Complete LLC	monthly contracted services	All	6,750.00
Credit	10/11/2024	101124	Complete LLC	charge for broken window - Truman Terrace	Truman Terrace	-450.00
Bill	10/28/2024	101477	Dumouchel Paper	supplies	All	145.17
Bill	11/01/2024	241101496101	Edwards Answering Service Enterprises Inc	monthly service	All	34.73
Bill	10/01/2024	5139 798 3032	Eversource	Service 09/03/24-10/01/24	Truman Terrace	117.97
Bill	10/11/2024	5179 146 4068	Eversource	Service 09/26/24-10/09/24	Country Ridge	9.73
Bill	10/22/2024	5151 346 4073	Eversource	Service 09/26/24-10/21/24	Truman Terrace	45.89
Bill	10/25/2024	5102 066 4066	Eversource	Service 10/21/24-10/25/24	Truman Terrace	21.05
Bill	10/25/2024	5113 818 3082	Eversource	Service 09/26/24-10/25/24	Truman Terrace	324.43
Bill	10/25/2024	5125 298 3036	Eversource	Service 09/26/24-10/25/24	Buckingham Terrace	595.96
Bill	10/25/2024	5129 979 3026	Eversource	Service 09/26/24-10/25/24	Country Ridge	33.88
Bill	10/25/2024	5131 089 3094	Eversource	Service 09/26/24-10/25/24	Country Ridge	52.26
Bill	10/25/2024	5135 689 3081	Eversource	Service 09/26/24-10/25/24	Country Ridge	517.27
Bill	11/01/2024	5139 798 3032	Eversource	Service 10/01/24-11/01/24	Truman Terrace	123.74
Bill	10/25/2024	5141 028 3030	Eversource	Service 09/26/24-10/25/24	Truman Terrace	50.75
Bill	10/25/2024	5141 089 3093	Eversource	Service 09/26/24-10/25/24	Country Ridge	52.33
Bill	10/25/2024	5144 889 3081	Eversource	Service 09/26/24-10/25/24	Country Ridge	30.18
Bill	10/25/2024	5147 056 4014	Eversource	Service 09/26/24-10/25/24	Country Ridge	37.22
Bill	10/25/2024	5152 818 3080	Eversource	Service 09/26/24-10/25/24	Truman Terrace	124.92
Bill	10/25/2024	5154 889 3080	Eversource	Service 09/26/24-10/25/24	Country Ridge	30.18
Bill	10/25/2024	5155 789 3047	Eversource	Service 09/26/24-10/25/24	Country Ridge	61.44
Bill	10/25/2024	5160 799 3003	Eversource	Service 09/26/24-10/25/24	Country Ridge	46.75
Bill	10/25/2024	5161 089 3091	Eversource	Service 09/26/24-10/25/24	Country Ridge	32.03
Bill	10/25/2024	5175 889 3077	Eversource	Service 09/26/24-10/25/24	Country Ridge	65.11
Bill	10/25/2024	5181 389 3054	Eversource	Service 09/26/24-10/25/24	Country Ridge	47.85
Bill	10/25/2024	5190 799 3000	Eversource	Service 09/26/24-10/25/24	Country Ridge	44.16
Bill	10/25/2024	5191 018 3029	Eversource	Service 09/26/24-10/25/24	Truman Terrace	116.37
Bill	10/28/2024	5741 865 0156	Eversource - Gas	Service 09/26/24-10/26/24	Country Ridge	36.40
Bill	10/28/2024	5760 163 0056	Eversource - Gas	Service 09/26/24-10/26/24	Country Ridge	140.31
Bill	10/28/2024	5784 051 0028	Eversource - Gas	Service 09/26/24-10/26/24	Country Ridge	50.50

11/11/2024
10:56 AM

Watertown Housing Authority
Accounts Payable
November 2024

Type	Date	Num	Name	Memo	Location	Amount
Bill	10/21/2024	102124	Good Old Boys Tree Service, LLC	CR removal of tree	Country Ridge	600.00
Bill	09/24/2024	6035 3221 5317 6031	Home Depot	6035 3221 5317 6031	Country Ridge & Truman Terrace	2,260.81
Bill	10/25/2024	6035 3221 5317 6031	Home Depot	6035 3221 5317 6031	All	3,317.90
Bill	10/09/2024	23531	J & J Lock LLC	TT service call	Truman Terrace	134.00
Bill	10/09/2024	07881-138731-01-1	Optimum BT	Service 10/15-11/14/24	Buckingham Terrace	246.37
Bill	10/09/2024	07881-134130-01-9	Optimum CR	Service 10/15-11/14/24	Country Ridge	285.90
Bill	10/09/2024	07881-138730-01-3	Optimum TT	Service 10/15-11/14/24	Truman Terrace	256.37
Bill	11/04/2024	8244	PJ Electric, Inc.	BT service call	Buckingham Terrace	75.00
Bill	11/04/2024	8241	PJ Electric, Inc.	CR service call	Country Ridge	121.40
Bill	10/21/2024	8203	PJ Electric, Inc.	CR 4 service call	Country Ridge	181.30
Bill	11/01/2024	5195	Propertyworx LLC	Nov 2024 management services	All	6,930.00
Bill	09/10/2024	25111adj	Ray Palmer Plumbing & Heating, Inc.	CR 37 check hot water	Country Ridge	17.36
Bill	10/01/2024	25130	Ray Palmer Plumbing & Heating, Inc.	BT C-8 service call	Buckingham Terrace	137.16
Bill	10/11/2024	25132	Ray Palmer Plumbing & Heating, Inc.	TT C-1 service call	Truman Terrace	80.00
Bill	10/16/2024	25131	Ray Palmer Plumbing & Heating, Inc.	CR 14,27,23 service calls	Country Ridge	1,109.24
Bill	10/03/2024	BT C-8	Steven L. Clark	BT C-8 remove tile around shower, install fibergl	Buckingham Terrace	3,650.00
Bill	09/30/2024	0603142032CR	USA Hauling & Recycling Inc	CR yearly cleanup	Country Ridge	735.00
Bill	11/01/2024	0603144237BT	USA Hauling & Recycling Inc	BT monthly service	Buckingham Terrace	437.23
Bill	11/01/2024	0603144238CR	USA Hauling & Recycling Inc	CR monthly service	Country Ridge	437.23
Bill	11/01/2024	0603144236TT	USA Hauling & Recycling Inc	TT monthly charge	Truman Terrace	502.40
Bill	10/24/2024	1020740 1024	Watertown Fire District	TT Service 09/16-10/15/24	Truman Terrace	317.41
Bill	10/01/2024	0304130000BT	Watertown WSA	BT 06/30/24-09/30/24	Buckingham Terrace	2,063.42
Bill	10/01/2024	0304132000CR	Watertown WSA	CR 06/30/24-09/30/24	Country Ridge	2,710.43
Bill	10/08/2024	4205	Worxshop LLC	Sep 2024 - Maintenance & Repairs BT	Buckingham Terrace	728.75
Bill	10/08/2024	4206	Worxshop LLC	Sep 2024 - Maintenance & Repairs CR	Country Ridge	3,863.75
Bill	10/08/2024	4207	Worxshop LLC	Sep 2024 - Maintenance & Repairs TT	Truman Terrace	3,217.50
Bill	11/11/2024	4258	Worxshop LLC	Oct 2024 - Maintenance & Repairs BT	Buckingham Terrace	1,746.25
Bill	11/11/2024	4259	Worxshop LLC	Oct 2024 - Maintenance & Repairs CR	Country Ridge	2,557.50
Bill	11/11/2024	420	Worxshop LLC	Oct 2024 - Maintenance & Repairs TT	Truman Terrace	1,993.75

59,047.57



New Business

2025

WATERTOWN HOUSING AUTHORITY

JANUARY 8

6:00 P.M. Buckingham Terrace

FEBRUARY 12

6:00 P.M. Truman Terrace

MARCH 12

6:00 P.M. Country Ridge

APRIL 9

6:00 P.M. Buckingham Terrace

MAY 14

6:00 P.M. Truman Terrace

JUNE 11

6:00 P.M. Country Ridge

JULY 9

6:00 P.M. Buckingham Terrace

AUGUST 13

6:00 P.M. Truman Terrace

SEPTEMBER 10

6:00 P.M. Country Ridge

OCTOBER 8

6:00 P.M. Buckingham Terrace

NOVEMBER 12

6:00 P.M. Truman Terrace

December 10

6:00 P.M. Country Ridge

WHA BOARD MEMBERS

Janelle Wilk – Chairwoman

Dan DeVito – Vice Chairman

Sharon Pratt – Treasure/Secretary

Denise Russ – Commissioner

Peter Mucciarone – Commissioner



Old Business

Attached is the proposal from Launderama, LLC.

After speaking to the representative of Launderama, it sounds that they have taken over many of the customers that used CSC.

From what I understand CSC is having financial problems and are losing employees.

The only down side I see with going with this new company is that they will pay a flat rate to WHA of \$3,600.00 per year. \$300.00 per quarter, per community.

In 2023 WHA received a total of \$4,629.00 from CSC. YTD thru Sept 2024 we have received \$3,471.00.

With the terrible response from CSC for repairs, maybe it would be worth the \$\$\$ reduction.



1616 Corbin Avenue, New Britain, CT 06053 David@LauderamaLLC.com 800-286-3500

~ Laundry Facilities Proposal ~
Watertown Housing Authority
1091 Buckingham Street, 935 Buckingham Street, 100 Steele Brook Road
Lori Finke 860-960-3459 Lori@PropertyWork.com

October 17, 2024

Laundry Equipment:

- Six (6) brand new Speed Queen top-load card-operated Washers
 - Stainless steel tubs / two-speed washers
 - Stainless steel burst proof water hoses
 - Energy Star Rated laundry equipment
- Six (6) brand new Speed Queen Mobile-APP card-operated electric Dryers
- One (1) Card Machine installed in each laundry room
 - The card machine does not dispense cards
 - Tenants will receive laundry cards from Property Manager
- Vend Price:
 - Wash: \$1.50 standard wash 29 minutes – spray rinse
\$1.75 longer wash 31 minutes – spray rinse
\$2.00 extra-long wash 39 minutes – full tub rinse
 - Dry: \$1.50 60-minute cycle
Buy additional 10 minutes of drying time for \$.25

Laundry Room Includes:

- Washer and dryer instruction sign
- Cleaning and reconstructing dryer vent system
- Performing yearly preventive maintenance to vent system and equipment

Commission Payments & Lease:

- Launderama will pay a flat rate commission as follows:
 - 1091 Buckingham Street: \$1,200 per year, payable in quarterly installments of \$300 each.
 - 935 Buckingham Street: \$1,200 per year, payable in quarterly installments of \$300 each.
 - 100 Steele Brook Road: \$1,200 per year, payable in quarterly installments of \$300 each.
- 10-year lease agreement

Service and Insurance:

- Call our 24-hour toll-free service telephone number or visit our website
- Provide same day service on equipment; most repairs will be completed in four business hours
- Our service vehicles are company marked and our technicians are uniformed, and factory trained
- Launderama assumes full responsibility if the equipment is vandalized
- Launderama is covered by a \$2,000,000 property and liability insurance policy

QUANTUM® GOLD PREP FOR CARD, COIN DROP INSTALLED, PREP FOR COIN COMMERCIAL REAR CONTROL SINGLE DRYER

Built for Reliable Performance

Speed Queen's dryer, defined by its simplicity and its performance, provides everything you need to get the job done - and nothing you don't. Speed Queen's single load dryers combine heavy-duty construction with reliable operation proven to stand the test of time. They're designed with less moving parts for one reason: so you'll face fewer maintenance problems and less wear and tear down the road. Speed Queen's dryers provide the perfect balance of heat, airflow and tumble action for optimal performance and efficiency.

- Integrated meter case
- Industry's largest door opening 2.06 sq. ft. (1914 cm²)
- Quiet, efficient blower system
- Door is reversible for installation flexibility
- High efficiency exhaust blower with superior airflow 220 cfm (105 liters/sec)
- 100% serviceable from the front
- Space-saving narrow cabinet 26.875" (683 mm)
- Upfront lint filter easy to clean and secured
- Durable galvanized steel cylinder
- Large capacity meter case standard

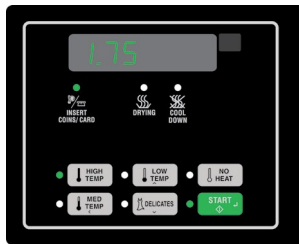

Cutting edge Quantum control system from Speed Queen gives you the freedom to manage laundry your way and the power to achieve unmatched levels of revenue. This revolutionary technology provides users with more cycle choices than ever, offers unprecedented options to help lower operating costs and incorporates tools and options to increase revenue.



SPECIFICATIONS

COMMERCIAL REAR CONTROL SINGLE DRYER

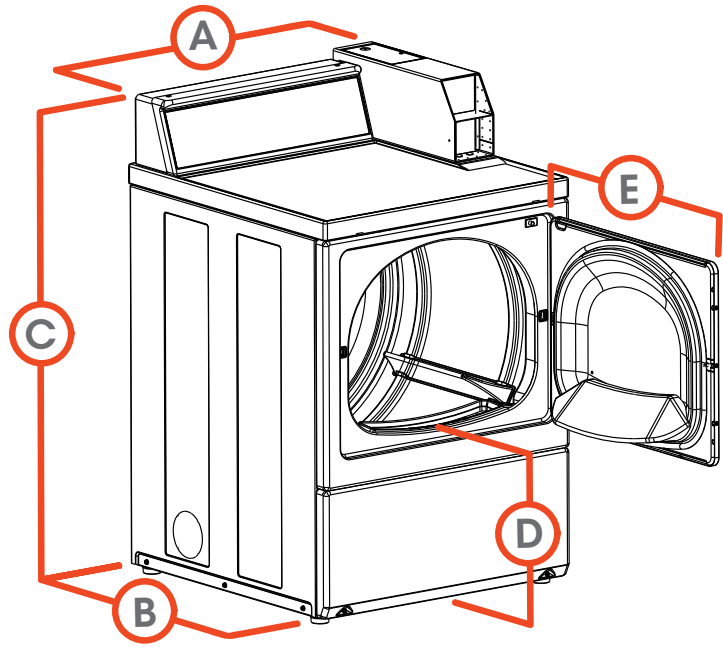
MODEL - see below for all models and activation available	
CONTROL OPTION	Quantum Gold
COLOR	Stainless
CAPACITY - lb (kg)	18 (8.2)
OVERALL WIDTH - in (mm)	26.875 (683)
OVERALL DEPTH - in (mm)	28 (711)
OVERALL HEIGHT - in (mm)	43 (1092)
CYLINDER VOLUME - cu. ft. (liters)	7.0 (198)
MOTOR (CAPACITOR START AND THERMAL PROTECTED)	.33 HP
TYPE OF GAS (GAS MODELS ONLY)	Factory equipped natural/mixed gas
AIR OUTLET DIAMETER - in (mm)	4 (102)
EXHAUST AIRFLOW - cfm (liters/sec)	220 (105)
AVAILABLE CYCLES	High, Medium, Low, Delicates, No Heat
ELECTRICAL REQUIREMENTS	Electric 120/240/60/1-30 amp 120/208/60/1-30 amp
	Gas 120/60/1-15 amp
HEATING ELEMENT	Electric 5350W, 240V 4750W, 208V
	Gas 25,000 Btu
NET WEIGHT - lb (kg)	Electric 150 (68)
	Gas 150 (68)
SHIPPING WEIGHT lb (kg)	Electric 161 (73)
	Gas 161 (73)
SHIPPING DIMENSIONS APPROX. - in (mm)	Width 30.5 (775)
	Depth 29.5 (749)
	Height 45 (1143)
AGENCY APPROVALS	Electric cULus
	Gas cCSAus



A. OVERALL WIDTH - in (mm)	26.875 (683)
B. OVERALL DEPTH - in (mm)	28 (711)
C. OVERALL HEIGHT - in (mm)	43 (1092)
D. FLOOR TO DOOR OPENING - in (mm)	15.44 (392)
E. DOOR SWING - in (mm)	23.5 (597)

MODELS	VOLTAGE/FREQ/PH	ACTIVATION		
SDENCRGS173TW02	120/240/60/1	Electric	Coin Drop Installed	
SDENCRGS153TW02	120/208/60/1			
SDGNCRGS113TW02	120/60/1	Gas		
SDENXRGS173TW02	120/240/60/1	Electric	Prep for Coin	
SDGNXRGS113TW02	120/60/1			
SDENYRGS173TW01	120/240/60/1	Electric	Prep for Card	
SDEWYRGS173TW01*	120/240/60/1			
SDENYRGS153TW01	120/208/60/1			
SDEWYRGS153TW01*	120/208/60/1			
SDGNYRGS113TW01	120/60/1			
SDGWYRGS113TW01*	120/60/1			

* Wireless Network Board Factory Installed

■ Electric dryers come equipped for 240/60/1 operation. They can be field converted to operate on 208/60/1 with optional 61928 conversion kit. Gas dryers can be field converted for operation on LP gas with optional 458P3 conversion kit.

For the most accurate information, the installation guide should be used for all design and construction purposes. Due to continuous product improvements, design and specifications subject to change without notice. The quality management system of Alliance Laundry Systems' Ripon facility has been registered to ISO 9001:2008.

SPEED QUEEN MULTI-HOUSING

QUANTUM® GOLD COIN DROP INSTALLED, PREP FOR COIN, PREP FOR CARD COMMERCIAL TOP LOAD WASHER PEAK PERFORMANCE

Built for Reliable Performance

Speed Queen's two-speed top load washer, defined by its simplicity and its performance, provides everything you need to get the job done – and nothing you don't. Speed Queen's top load washer combines heavy-duty construction with reliable operation proven to stand the test of time. Speed Queen washers provide maximum energy efficiency and long-lasting performance.

- Touch pad control with sound annunciator
- 27 cycle selections
- Extract speed of 710 RPM spins clothes out drier
- Integrated meter case
- Advanced suspension system
- Easy-to-read digital display
- Cycle programming flexibility
- Multi-level vend pricing
- Individual cycle modifier keys
- Durable stainless steel tub standard
- 2.83 cu. ft. (80.14 liters) wash capacity
- Large capacity meter case standard
- Wash Alert™ capability

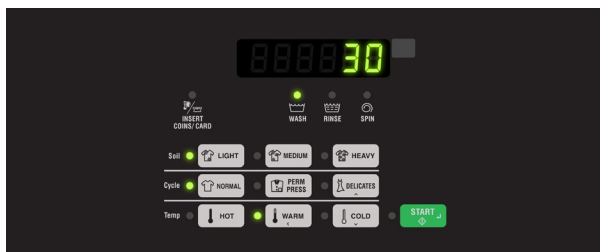

The cutting edge Quantum control system from Speed Queen gives you the freedom to manage laundry your way with the power to achieve unmatched levels of revenue. Quantum Gold provides users with additional cycle choices while offering new options to help lower operating costs and incorporates tools and options to increase revenue.



SPECIFICATIONS

COMMERCIAL TOP LOAD WASHER PEAK PERFORMANCE

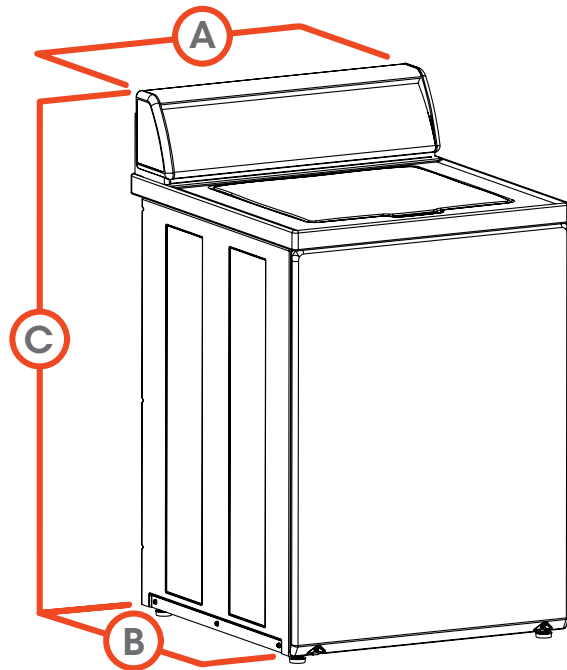
MODEL - see below for all models and activation available	
CONTROL OPTION	Quantum Gold
COLOR	White
CAPACITY - lb (kg)	14 (6.4)
OVERALL WIDTH - in (mm)	25.63 (651)
OVERALL DEPTH - in (mm)	28 (711)
OVERALL HEIGHT - in (mm)	43 (1092)
CYLINDER VOLUME - cu. ft. (liters)	2.83 (80.14)
SPIN SPEED G-FORCE (RPM)	150 (710)
MOTOR SIZE - HP (kw)	0.5 (0.37)
WATER CONSUMPTION PER CYCLE - g (liter)	24.9 (94.3)
IWF (WATER FACTOR) - gal/ft ³ (liters/liter/cycle)	8.8 (1.18)
MEF ₁₂ (Modified Energy Factor) ft ³ /kWh/cycle (Liters/kWh/cycle)	1.35 (38.2)
AVAILABLE WATER TEMPERATURES	Hot, Warm, Cold
AVAILABLE CYCLES	Light, Medium, Heavy, Small Load, Normal, Perm Press, Delicate
ELECTRICAL REQUIREMENTS (v/Hz/Ph-Amp)	120/60/1 - 15 Amp
WATER PRESSURE - p.s.i. (bar)	20-120 (1.4/8.3)
DRAIN	Pump
CYLINDER FINISH	Stainless Steel
NET WEIGHT - lb (kg)	206 (93.4)
SHIPPING WEIGHT - lb (kg)	218 (98.8)
SHIPPING DIMENSIONS APPROX. - in (mm)	Width 28 (711)
	Depth 30 (762)
	Height 45 (1143)
AGENCY APPROVALS	cULus



A.	OVERALL WIDTH - in (mm)	25.625 (651)
B.	OVERALL DEPTH - in (mm)	28 (711)
C.	OVERALL HEIGHT - in (mm)	43 (1092)

MODELS	ACTIVATION	
SWNNC2HP115TW02	Coin Drop Installed	
SWNNX2HP115TW02 SWNWX2HP115TW02*	Prep for Coin	
SWNNY2HP115TW01 SWNWX2HP115TW01*	Prep for Card	

*Wireless Network Board Factory Installed

For the most accurate information, the installation guide should be used for all design and construction purposes. Due to continuous product improvements, design and specifications subject to change without notice. The quality management system of Alliance Laundry Systems' Ripon facility has been registered to ISO 9001:2000.



by Alliance Laundry Systems

speedqueencommercial.com/multihousing

AM18-0035 • ©2018 Alliance Laundry Systems LLC



Property Manager Update

Open Apartments as of November 8, 2024

Complex	Unit #	Condition / Necessary Work	Comment
Country Ridge			
Full			
Buckingham Terr.			
1			
	D2	Vacated by tenant transfer	Apartment is being updated
Truman Terrace			
1	C-12		Apartment is being updated
New Tenants since 11/1/2020			
Country Ridge			
	31	Irene Lucewicz	12/1/2020
	34	Charles Mordenti (Wife passed 1/21)	1/1/2021
	32	Claire Cipriano	10/1/2021
	26	Mario Mancini	7/1/2022
	34	Louella Plaut	8/15/2022
	40	Arnold Torretta	3/1/2023
	7	Edward & Lynn Marti	3/1/2024
	4	Nancy Brooks	8/1/2024
	14	Andrea Smith	9/1/2024
Buckingham Terr			
	B-5	Chiarini Orsini	11/15/2020
	B-2	Wendy Cote	1/15/2021
	C-2	Margret Hillman	3/1/2021
	C-6	Valerie Whitford	5/1/2021
	C-5	Steven Pappineau	6/1/2021
	A-6	Thomas St. Onge	8/15/2021
	C-4	Domenic Petro	9/1/2021
	D-2	Mark Rayel	6/1/2022
	A-2	Josephine Brantmeyer	11/1/2022
	A-3	Kevin Kiefer	6/1/2023
	B-7	Phyllis West	9/15/2023
	D4	Tanya Johnson	11/1/2023

	A-6	Mark Docchio	1/1/2024
	A-7	Elsa Williams	1/1/2024
	C-7	Menuhkisqua Benedict	3/1/2024
	B-5	Anthony Faressa	11/15/2024
Truman Terr.			
	C-13	Judith Wrogg	12/1/2020
	C-11	Robin Lynn Teach	4/1/2021
	C-17	Francis Membrino	4/1/2021
	C-1	Gertrude Druan	8/15/2021
	A-8	Lisa Perrucci	9/1/2021
	B-2	Diane Lautenschlager	9/1/2021
	B-5	Roger Anctil	10/15/2021
	B-10	Maureen Murray	11/12/2021
	B-1	Rosemary Ann LoRusso	12/17/2021
	B-4	William Behr	12/17/2021
	B-1	Keivn Pzafer	8/1/2022
	C-19	Edmond Charette	9/1/2022
	C-15	Madeline DiStiso	9/1/2022
	B-12	Janice Gentil	11/1/2022
	A-3	Patricia Nielson	3/1/2023
	B-1	Janine Kiefer	5/1/2023
	A-8	Samuel McCleary	5/15/2023
	B-7	Jeffery Grenier	9/1/2023
	C-6	Nancy Woodward	10/15/2023
	B-5	Anthony Raimo	1/1/2023
	C-7	Tony and Cathy Macelis	6/21/2024
	C-16	Martin Finley	6/10/2024
Transfers			
Buckingham Terr.	A-6 - A1	Marza Noss	12/12/2020
Truman Terr.	C-15 - C-5	Ayriye Osman	8/1/2021
Truman Terr.	B-1 - C-14	Keivn Dzafer	11/1/2022
Buckingham Terr.	A- 6 - B-2	Tom St. Onge	12/15/2022
Truman Terr	B-7 - C-9	Karen Searles	1/4/2023
Truman Terr	C-16- B4	Richard Gaynor	7/1/2023

Country Ridge	CR14 - CR20	Gloria Rossi	5/5/2024
Country Ridge	D-2 - 22	Mark Rayel	11/1/2024
Truman Terr.	C12 - A1	Thomas Wills	11/1/2024

WO #	Created On	Completed On	Work Order Title	Work Order Description	Status
1973	11/11/2024		CR Flag pole - Please put up a new flag.	Please put up a new flag.	Open
1974	11/11/2024		TT C-1 Tub needs a screen for drain	Tub needs a screen for drain	Open
1971	11/07/2024		BT A-5 Mold under the kitchen sink	Please do necessary repairs to remove mold from under the kitchen sink.	Open
1969	11/06/2024		CR 12 Bathroom Exhaust fan - check	Please check out the bathroom exhaust fan. On the list to be cleaned but now tenant is saying it isn't working.	Open
1970	11/06/2024		TT B-5 Check to see if freezer is working.	Please check to see if the freezer is holding the correct temperature.	Open
1966	11/01/2024	11/01/2024	BT A-5 Bathroom sink is backed up with black water	Please snake out and repair the sink piping. Black water is backing up into the sink.	Complete
1967	11/01/2024	11/05/2024	CR CC replace screws on outside button	Replace screws on outside button.	Complete
1963	10/29/2024	11/01/2024	CR 21 Replace light bulb outside - front door	Please replace the light bulb in the outside fixture - main door.	Complete
1964	10/29/2024		CR 20 Please add electronic device to scare animals from attic.	Please add electronic device to scare animals from attic.	Open
1965	10/29/2024	11/01/2024	BT A-3 Toilet is leaking on the floor	Please check out the toilet - leaking water on the bathroom floor.	Complete
1962	10/28/2024		Country Ridge - Repairs from inspection	Repairs from inspection	Open
1959	10/28/2024	11/01/2024	TT B1 (1) outlet needs to be replaced - loose	Please replace an out let. It is worn.	Complete
1954	10/21/2024		TT lower picnic area - needs to be cleaned up	I will need to ask Commission what they would like to be done with the items in this area.	Open
1953	10/21/2024	11/05/2024	TT A1 Kitchen shade will not stay up	Please fix the shade in the kitchen. It will not stay in the up position.	Complete
1951	10/17/2024		Truman Terrace - repairs from inspections	Please make the necessary repairs for issues found during the October inspections.	Open
1950	10/17/2024	10/21/2024	BT E2 Toilet will not flush	Please check out the toilet. Bowl is filled to the top and will not flush.	Complete
1952	10/17/2024	10/22/2024	CR 10 Kitchen light needs bulbs	Please replace the bulbs in the light - kitchen ceiling.	Complete
1945	10/16/2024	10/21/2024	TT C-12 - A1 Relocate Refrigerator and stove	Please move the refrigerator and stove from C12 - A1.	Complete
1943	10/16/2024	10/16/2024	CR 31 Please kill bees, spray and get rid of nest	Please kill bees, spray and get rid of nest.	Complete
1946	10/16/2024	10/21/2024	CR CC ladies room door handle	Please tighten door handle on ladies room.	Complete
1948	10/16/2024	10/23/2024	TT C20 Toilet runs	Toilet runs, please repair.	Complete
1941	10/14/2024	10/22/2024	CR 40 apartments	Conduct 40 indoor inspection at Country Ridge with Lori.	Complete
1942	10/14/2024	10/23/2024	CR 29 Bathroom Sink is leaking	Please replace the sink with vanity. This sink has had leaks in the past.	Complete
1940	10/09/2024	10/15/2024	CR 19 Replace from screen door - rotted	Replace from screen door - rotted.	Complete
1939	10/09/2024	10/23/2024	TT A-8 Bathroom sink draining slowly	Please check out the bathroom sink, draining slowly.	Complete
1937	10/02/2024	10/07/2024	BT B-2 Kitchen light is out	Please replace the bulb in the kitchen light.	Complete
1938	10/02/2024	10/07/2024	CR 24 Kitchen sink is draining slowly	Check the kitchen sink - draining slowly.	Complete